

Priming pumps

Prime pumps after installing the pumps on the proper containers as directed on the reverse side of this sheet. Place a mixing cup under the pumps when priming. Prime each pump by pushing the head down until you feel resistance. Release the pump and allow it to return to the top of the stroke. After a short pause, push the head down again until you feel resistance, then release.

The point of resistance should be higher after each stroke until, after several strokes, resistance is met at the top of the stroke. All of the air in the pump should now be displaced with fluid. The fully primed pump will produce a continuous stream of resin or hardener with a slow steady stroke of the pump. After extended periods of rest, the pumps may require re-priming.

Metering resin and hardener

VERY IMPORTANT! When metering resin and hardener, depress each pump head fully and continuously to the bottom of its stroke. Allow the pump heads to return completely to the top of the stroke. Partial pump strokes will give the wrong ratio.



PUMP ONE FULL STROKE OF RESIN FOR EACH FULL STROKE OF HARDENER to meter the proper resin/hardener ratio.

Always use the same number of full strokes from each pump. Do not attempt to adjust the cure rate by altering the ratio. Refer to the WEST SYSTEM *User Manual & Product Guide* for tips on controlling cure time.

Before using pumps to meter epoxy for a project, it is a good idea to meter and mix a small test batch of epoxy to assure the pumps are operating properly and to observe the mixture's curing characteristics under your current working conditions. The mixture should cure to a hard solid over night at room temperatures and warmer. Refer to the Hardener Selection Guide in the *User Manual & Product Guide* or on the back of the 105 Resin container for specific hardener cure times.

If you have used equal numbers of full resin and hardener strokes, and your pumps are operating properly, the resin and hardener containers will empty at about the same time. If you have a substantial amount of resin or hardener left over when you run out of the other, check the pumps to be sure they are operating properly. Also re-check the dimension between the bottom of the pump head and the top of the plastic cap as shown on the Group Size B illustration on the reverse side. If dimensions do not match those shown or if the pumps do not operate properly, contact the technical staff at Gougeon Brothers.

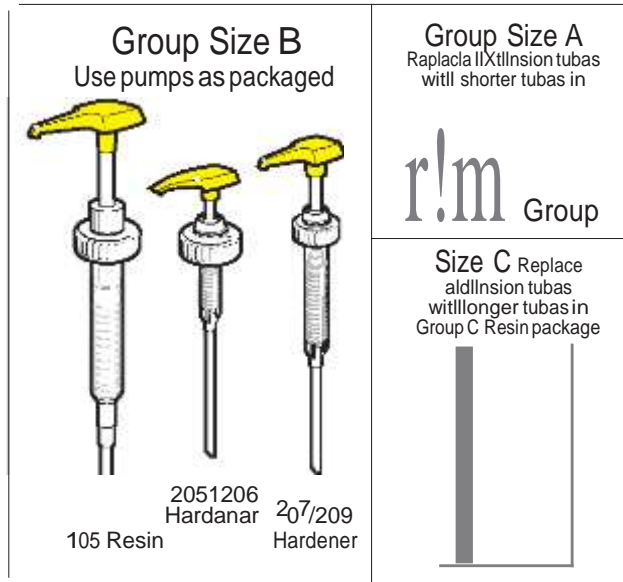

Operating pumps in cold temperatures

Cold temperatures cause a substantial increase in the viscosity of the resin and hardeners, requiring more force to pump the thicker materials. For best dispensing, keep the resin and hardener at room temperature. In cool temperatures, depress the pumps more slowly and allow extra time for pumps to return to the top of the stroke.

Storing and cleaning

Pumps may be left on the containers during storage. Store resin and hardener in a dry location at room temperature. Keep containers upright to prevent leaks. After a long storage, pumps may need to be re-primed. Pumps should not need cleaning during regular use. After a long storage, dried resin or hardener may plug the spout opening. If necessary, use a stiff wire to clear the opening.

For detailed information on WEST SYSTEM products or epoxy handling and applications, refer to the WEST SYSTEM *User Manual & Product Guide* or contact:



Gougeon Brothers Inc.
P.O. Box 908
Bay City, MI 48707 USA
866-937-8797 / westsystem.com

<C12014 Gougeon Brothers Inc.
R&O-060 M0214

WEST SYSTEM®

300 MINI PUMP SET

For the convenient and reliable metering of WEST SYSTEM 105 Resin and WEST SYSTEM Hardeners in Group Size A, B and C containers.

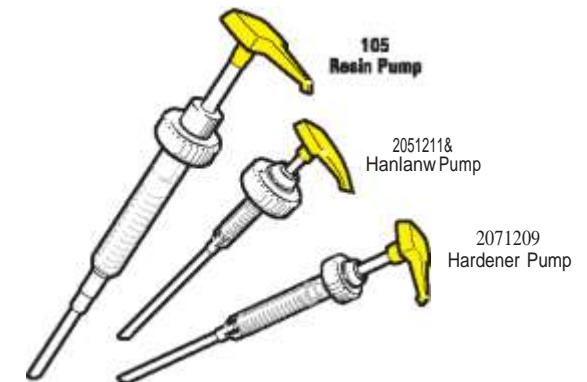

Operating Instructions

This package contains all of the parts required for metering Group Size A and B Resins and Hardeners. Additional parts required for Group Size C metering are included in the 105-C Resin, 207-SC and 209-SC Hardener packages.

**Read all instructions
before using pumps.**

WARNING! Use 300 Mini Pumps ONLY with other (yellow-headed) 300 Mini Pumps. Do not use with any white-headed pumps.

For Group Size B containers Pumps fit containers as packaged

D Identify pumps. Note printing on pump heads and extension tube lengths. Confirm dimensions between pump heads and caps.

Group Size A parts package

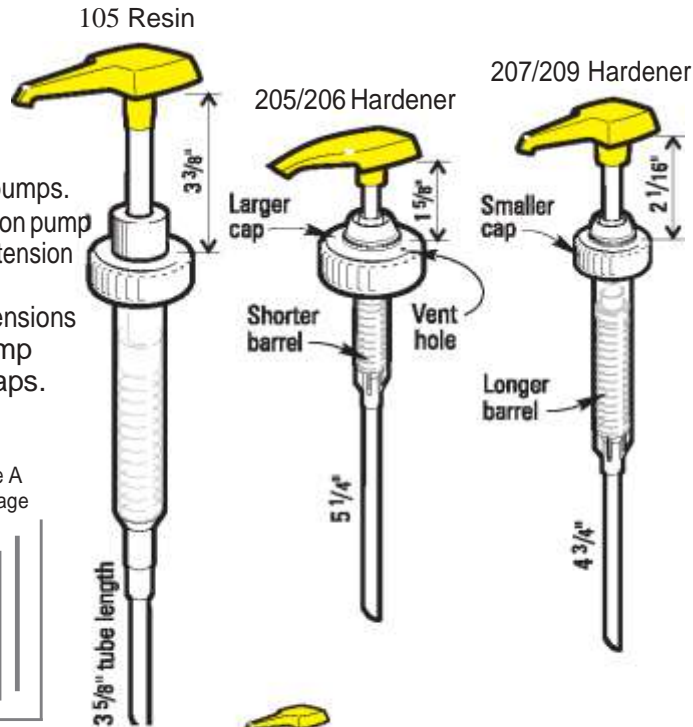

E) Install pumps as packaged onto appropriate Group Size B containers. Follow directions on the reverse side of this sheet for priming and metering.

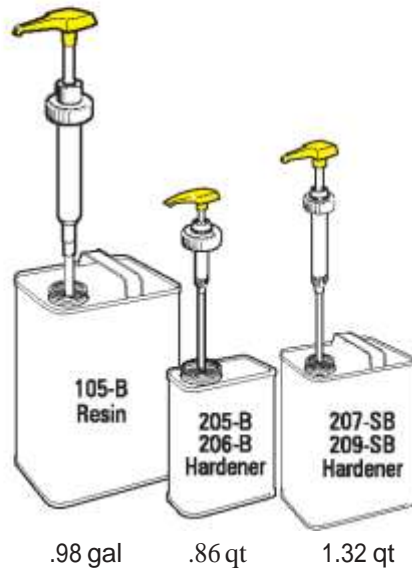

For Group Size A containers Modify pumps as follows

D Identify pumps. Refer to Group Size B diagram (left).

E) Remove attached extension tubes and set aside.



EJ Replace with shorter extension tubes included in Group Size A parts package as illustrated-Note tube lengths. Use BLUE extension tube in resin pump only

I Install modified pumps onto appropriate Group Size A containers. Follow directions on the reverse side of this sheet for priming and metering.

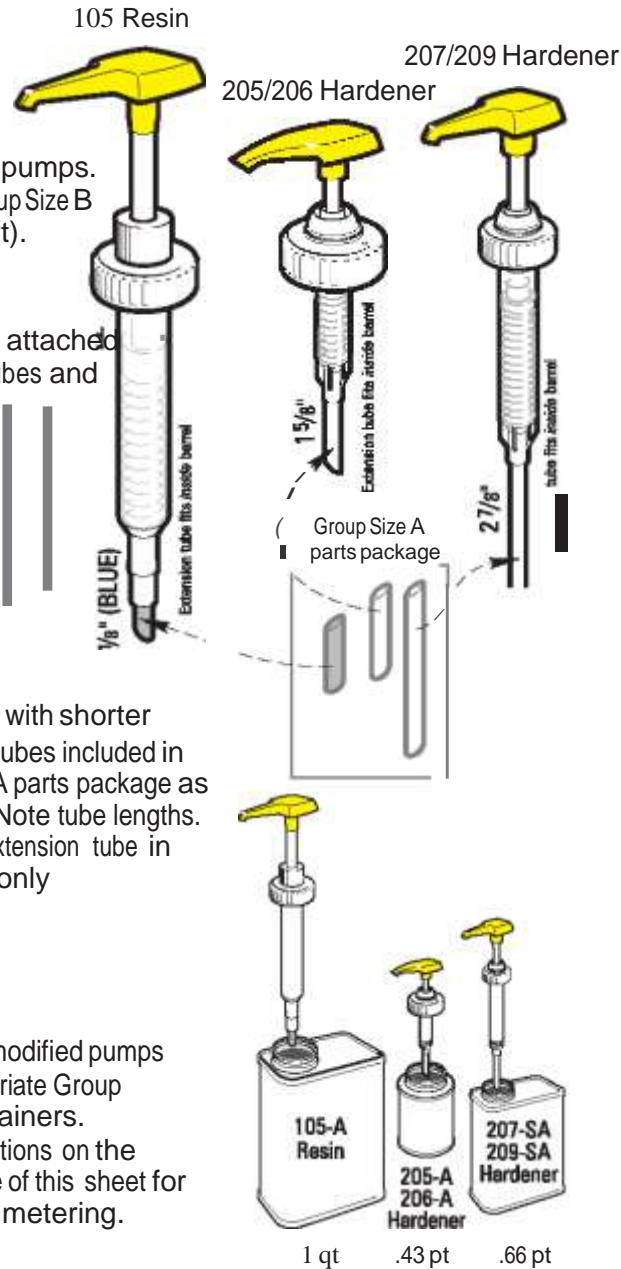

For Group Size C containers, see instructions in the 105-C and 207-SC or 209-SC packages.

Look for these parts included in the 105-C Resin package.

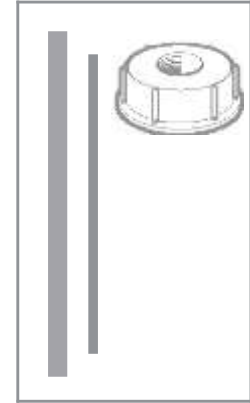

Look for these parts included in the 207-SC Hardener package.

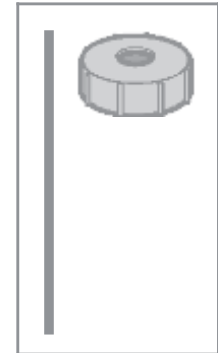

If the parts shown above are not included in the 105-C, 207-SC or 209-SC package, contact Gougeon Brothers to receive free replacement parts. Call 866-937-8797.